

THOR Motor Coach Palazzo

Floor plans: 37.4, 37.5, 37.6

5-STAR FEATURES



24/7 factory-direct phone support

DRIVETECH

Wheel and column controls pair with OptiView to put every command in easy reach

All-new ergonomic steering wheel

Prioritizes driver safety

V-RIDE

Increased towing capacity

Superior roll stability & handling

Greater durability & longevity

ENGINE

Make	Cummins B6.7
Horsepower	340 HP @ 2,600 rpm
Torque	700 lb-ft
Brake	VGT (Variable Geometry Turbocharger) Brake (single stage)

WEIGHT RATINGS

Front GAWR	12,000 lbs
Rear GAWR	20,000 lbs
Tag GAWR	N/A
Total GVWR	32,000 lbs
Total GCWR	33,000 lbs

TRANSMISSION

Type	Automatic
Gears	Allison 2500 6-speed

FUEL

Type	Diesel
Fuel Tank	90 Gallon
Def Tank	13 Gallon

SUSPENSION

Front	NEWAY
Wheel Cut	55 Degree front wheel
Rear	V-Ride

SHOCKS

Make	Sachs custom tuned
-------------	--------------------

AXLES

Front	Detroit DA-F-12.0-3
Rear	Detroit DA-RS-20.0-4

BRAKES

Front	Meritor CAM Brakes with ABS
Rear	Meritor CAM Brakes with ABS

COOLING

Radiator	1,335 sq. in., Rear mounted
-----------------	-----------------------------

RAILS

Straight	9.125" x 2.81" x 0.3125"
-----------------	--------------------------

FRAME

Construction	Straight rail with lowered rear section
Wheel Base	256"

HITCH

Rating	Supplied by OEM
---------------	-----------------

TIRES

Make	Michelin XZE2
Front Size	275/80R 22.5 14-ply
Rear Size	275/80R 22.5 14-ply
Wheels	8.25" Aluminum

ELECTRICAL

Alternator	160 Amp
Battery	(2) 1,900 CCA @ 0 degrees F

CONTROLS

Steering Column	ZF Tilt/Telescoping with Foot Pedal
Steering Wheel	DriveTech steering wheel w/ dash controls
Instruments	OptiView LCD display, Daytime Running Lights and TPMS

Some Roadwatch features may be optional. See your sales associate for more information.

WARRANTY

Basic Chassis / Drivetrain	5 years, 100,000 mi
Engine	5 years, 100,000 mi
Transmission	5 years, 200,000 mi
Battery	1 year, 100,000 mi
Corrosion / Brightwork	6 months unlimited
Frame Rails / Cross Member	5 years, 100,000 mi

THOR Motor Coach Palazzo

Floor plans: 37.4, 37.5, 37.6

5-STAR FEATURES



SERVICE

The RV industry's most comprehensive service and support coverage with **450+ Freightliner service locations, 90+ Oasis RV Specialist locations and 24/7 Factory-Direct support for the life of the coach.**

24/7 factory-direct service — talk directly with factory service advisors who average 18 years of experience.



Nationwide parts distribution centers (PDC Centers) provide expedited parts delivery through centralized Freightliner parts database.



- 24/7 Direct: free mobile app for one click, on-the-go support is available on Apple and Android — search "Freightliner 24/7"
- Call or email FCCC technicians 24/7, locate servicing dealers, and provide feedback on service experience
- Allows maintenance logs to be stored in the cloud and shared across devices
- Provides access to service checklist, owner and maintenance manuals, dash light descriptions, FAQs and more

DRIVETECH

DriveTech rolls together FCCC's latest innovations — like the OptiView all-digital LCD dash display, RoadWatch state-of-the-art safety systems, and FCCC's all-new ergonomic steering wheel and column-mounted controls — into one comfortable, easy-to-use drive console.



THOR Motor Coach Palazzo

Floor plans: 37.4, 37.5, 37.6

5-STAR FEATURES



OPTIVIEW™

Influenced by Mercedes-Benz®, OptiView™ is the first LCD instrument cluster in the RV industry, featuring:

- **Improved interface and steering wheel controls** with anti-glare display, bright graphics, colors, and menus
- **Bluetooth® connectivity** capability

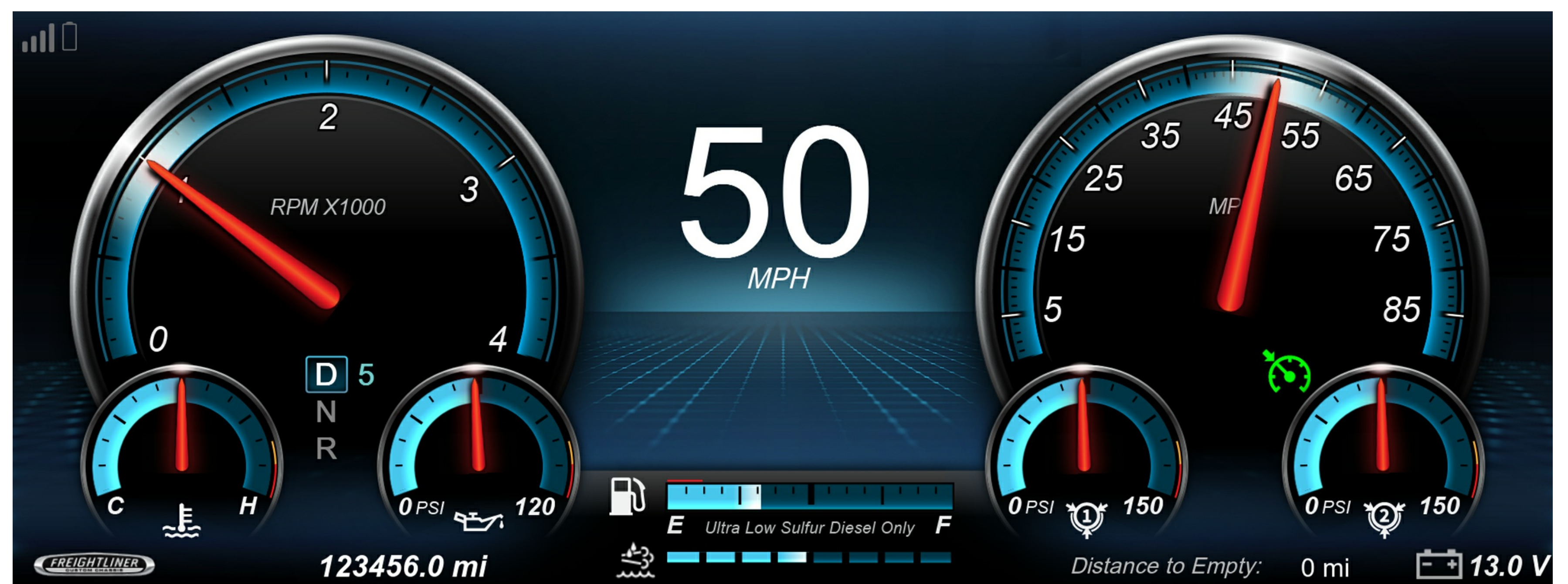

V-RIDE

Exclusive rear suspension system rated up to 24,000 lbs. for best-in-class cargo capacity, roll stability and overall handling.

- **More towing capacity** and consistent handling
- V-rod connection dissipates suspension forces — **reducing stress for greater durability and longevity**
- Transverse beam integrated with the trailing arm form a single-piece U-shaped assembly — **enhancing stability at all speeds while adding durability and reducing maintenance**

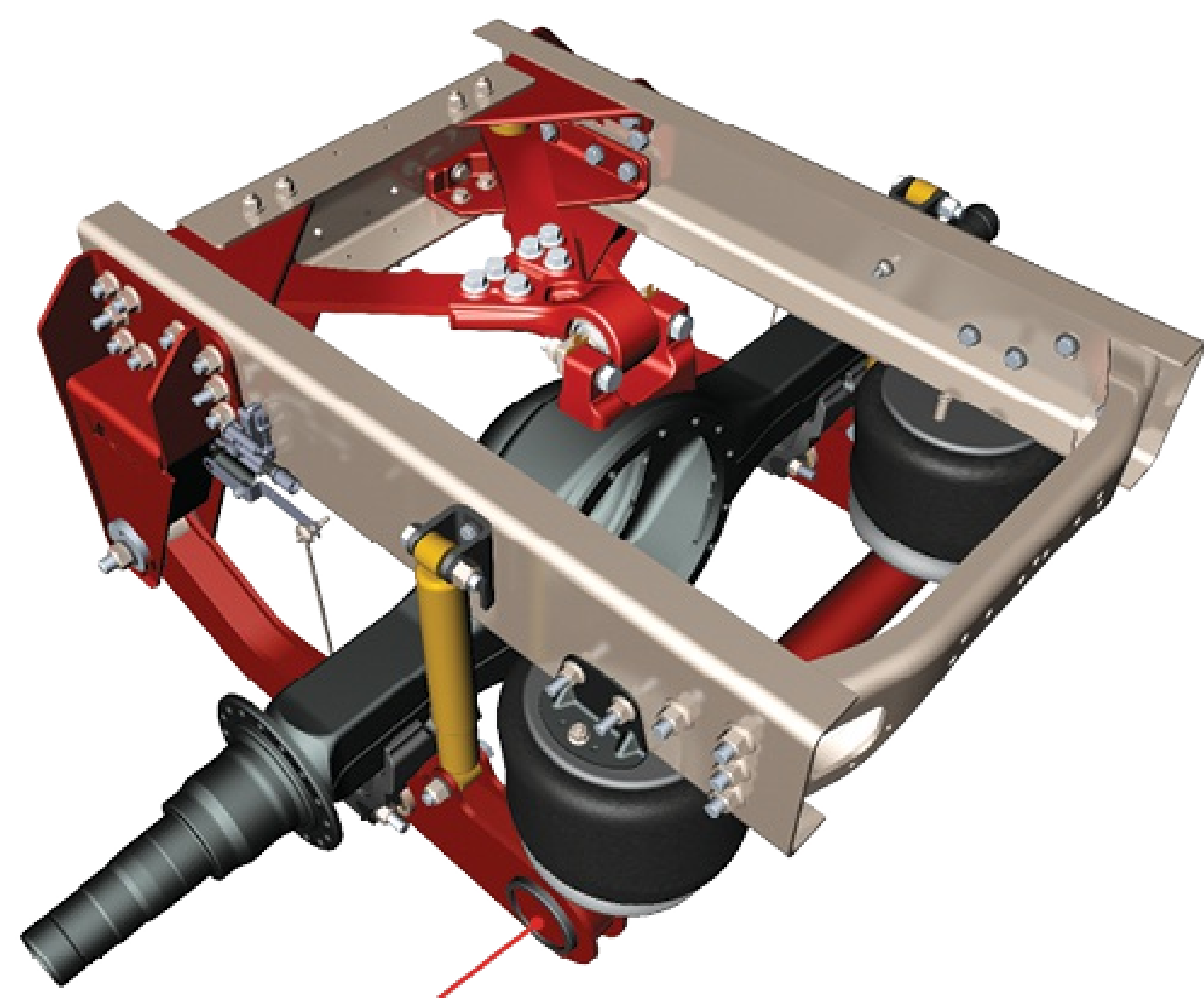

INTEGRATED TRANSVERSE BEAM

THOR Motor Coach Palazzo

Floor plans: 37.4, 37.5, 37.6

5-STAR FEATURES



EXPERIENCE OF OWNERSHIP

FREIGHTLINER CHASSIS OWNERS CLUB (FCOC):

- **10,000+ Members**
- **Parts and labor discounts** at select Freightliner service locations
- **Nationwide rallies and events** offer excursions to great destinations
- FCOC's comprehensive communications keep owners informed
 - Quarterly RV Soul magazine published 4x per year
- Members can **purchase Dodge, Chrysler or Jeep at 1% below dealer cost**



OWNER TRAINING

- **30+ Camp Freightliner I classes** at FCCC factory or on-site at rallies every year — comprehensive 2-day training with one-on-one coaching
- Camp Freightliner II classes at FCCC factory— **pairs owners with a service technician** in the service bay to observe service techniques and ask questions about their chassis
- Fireside Chat seminars — abbreviated training offered at all major rallies and shows

