

THOR Motor Coach Venetian Tag

Floor plans: B42, F42

5-STAR FEATURES



24/7 factory-direct phone support

DRIVETECH

Wheel and column controls pair with OptiView to put every command in easy reach

All-new ergonomic steering wheel

Prioritizes driver safety

ULTRASTEER

Reduced curb-to-curb turning radius

Eliminates costly tire scrub

Fully integrated & precision tuned to coach model & floorplan

V-RIDE

Increased towing capacity

Superior roll stability & handling

Greater durability & longevity

ENGINE

Make	Cummins L9
Horsepower	400 HP @ 2,100 rpm
Torque	1,250 lb-ft
Brake	Engine Compression Brake (three stage)

WEIGHT RATINGS

Front GAWR	14,700 lbs
Rear GAWR	20,000 lbs
Tag GAWR	10,000 lbs
Total GVWR	44,700 lbs
Total GCWR	59,700 lbs

TRANSMISSION

Type	Automatic
Gears	Allison 3000 6-speed

FUEL

Type	Diesel
Fuel Tank	100 Gallon
Def Tank	13 Gallon

SUSPENSION

Front	NEWAY
Wheel Cut	55 Degree front wheel
Rear	V-Ride
Tag	Ultra Steer

SHOCKS

Make	Sachs custom tuned
-------------	--------------------

AXLES

Front	Detroit DA-F-14.7-3
Rear	Detroit DA-RS-21.0-4
Tag	UltraSteer

BRAKES

Front	Bendix Air Disc Brakes with ABS
Rear	Bendix

COOLING

Radiator	1,335 sq. in., Rear mounted
-----------------	-----------------------------

RAILS

Front	9.0" x 2.75" x 0.25"
Upper	9.0" x 2.75" x 0.25"
Rear	9.0" x 2.75" x 0.25"

FRAME

Construction	Raised rail with lowered rear section
Wheel Base	266"

HITCH

Rating	15,000 lbs
---------------	------------

TIRES

Make	Michelin X Coach Z
Front Size	295/80R 22.5 16-ply
Rear Size	295/80R 22.5 16-ply
Tag Size	295/80R 22.5 16-ply
Wheels	8.25" Aluminum

ELECTRICAL

Alternator	160 Amp
Battery	(2) 1,900 CCA @ 0 degrees F

CONTROLS

Steering Column	ZF Tilt/Telescoping with Foot Pedal
Steering Wheel	DriveTech steering wheel with dash controls
Instruments	OptiView LCD display, Daytime Running Lights, Push Button Start, Suspended Brake and Accelerator Pedals and TPMS

WARRANTY

Basic Chassis / Drivetrain	5 years, 100,000 mi
Engine	5 years, 100,000 mi
Transmission	5 years, 200,000 mi
Battery	1 year, 100,000 mi
Corrosion / Brightwork	6 months unlimited
Frame Rails / Cross Member	5 years, 100,000 mi

THOR Motor Coach Venetian Tag

Floor plans: B42, F42

5-STAR FEATURES



SERVICE

The RV industry's most comprehensive service and support coverage with **450+ Freightliner service locations, 90+ Oasis RV Specialist locations and 24/7 Factory-Direct support for the life of the coach.**

24/7 factory-direct service — talk directly with factory service advisors who average 18 years of experience.



Nationwide parts distribution centers (PDC Centers) provide expedited parts delivery through centralized Freightliner parts database.



- 24/7 Direct: free mobile app for one click, on-the-go support is available on Apple and Android — search "Freightliner 24/7"
- Call or email FCCC technicians 24/7, locate servicing dealers, and provide feedback on service experience
- Allows maintenance logs to be stored in the cloud and shared across devices
- Provides access to service checklist, owner and maintenance manuals, dash light descriptions, FAQs and more

DRIVETECH

DriveTech rolls together FCCC's latest innovations — like the OptiView all-digital LCD dash display, RoadWatch state-of-the-art safety systems, and FCCC's all-new ergonomic steering wheel and column-mounted controls — into one comfortable, easy-to-use drive console.



THOR Motor Coach Venetian Tag

Floor plans: B42, F42

5-STAR FEATURES



OPTIVIEW™

Influenced by Mercedes-Benz®, OptiView™ is the first LCD instrument cluster in the RV industry, featuring:

- **Improved interface and steering wheel controls** with anti-glare display, bright graphics, colors, and menus
- **Bluetooth® connectivity** capability



ULTRASTEER

Precision-tuned tag axles follow the ideal turning path, eliminating tire scrub and reducing curb-to-curb turning radius by 17%;

- 12-degree wheel cut allows tag axle to follow the ideal turning path of the coach — **20% tighter turning angle than the nearest competitor**
- Outboard-mounted shocks offer **best-in-class roll stability, greatly enhancing ride and handling**
- Wide track suspension arms (B-Series) provide increased lateral stiffness for **improved handling in sudden maneuvers**
- Auto-locks at 20mph and in reverse; locking-pin utilizes air chamber and dedicated plate for **increased safety**

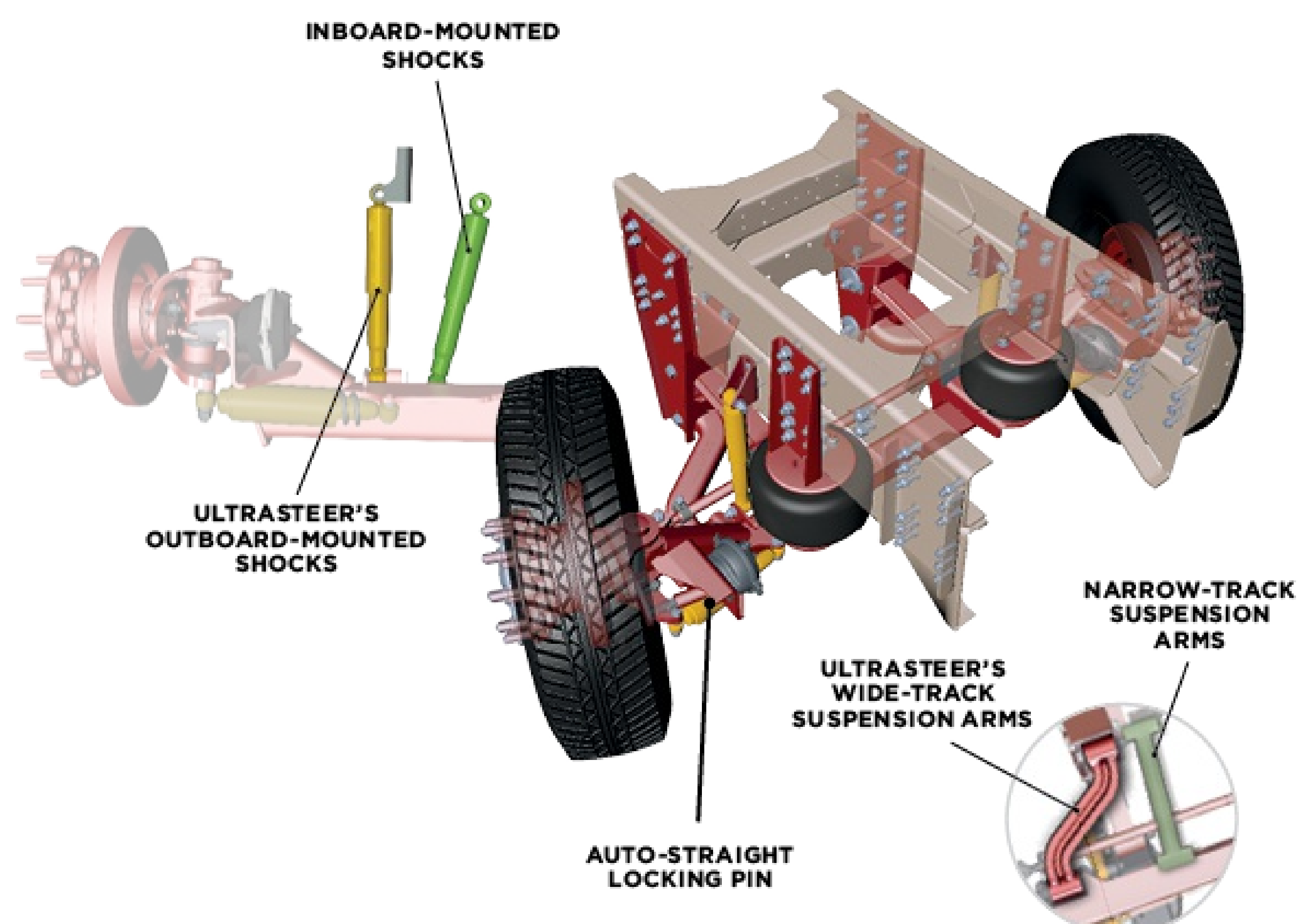

THOR Motor Coach Venetian Tag

Floor plans: B42, F42

5-STAR FEATURES



V-RIDE

Exclusive rear suspension system rated up to 24,000 lbs. for best-in-class cargo capacity, roll stability and overall handling.

- **More towing capacity** and consistent handling
- V-rod connection dissipates suspension forces — **reducing stress for greater durability and longevity**
- Transverse beam integrated with the trailing arm form a single-piece U-shaped assembly — **enhancing stability at all speeds while adding durability and reducing maintenance**

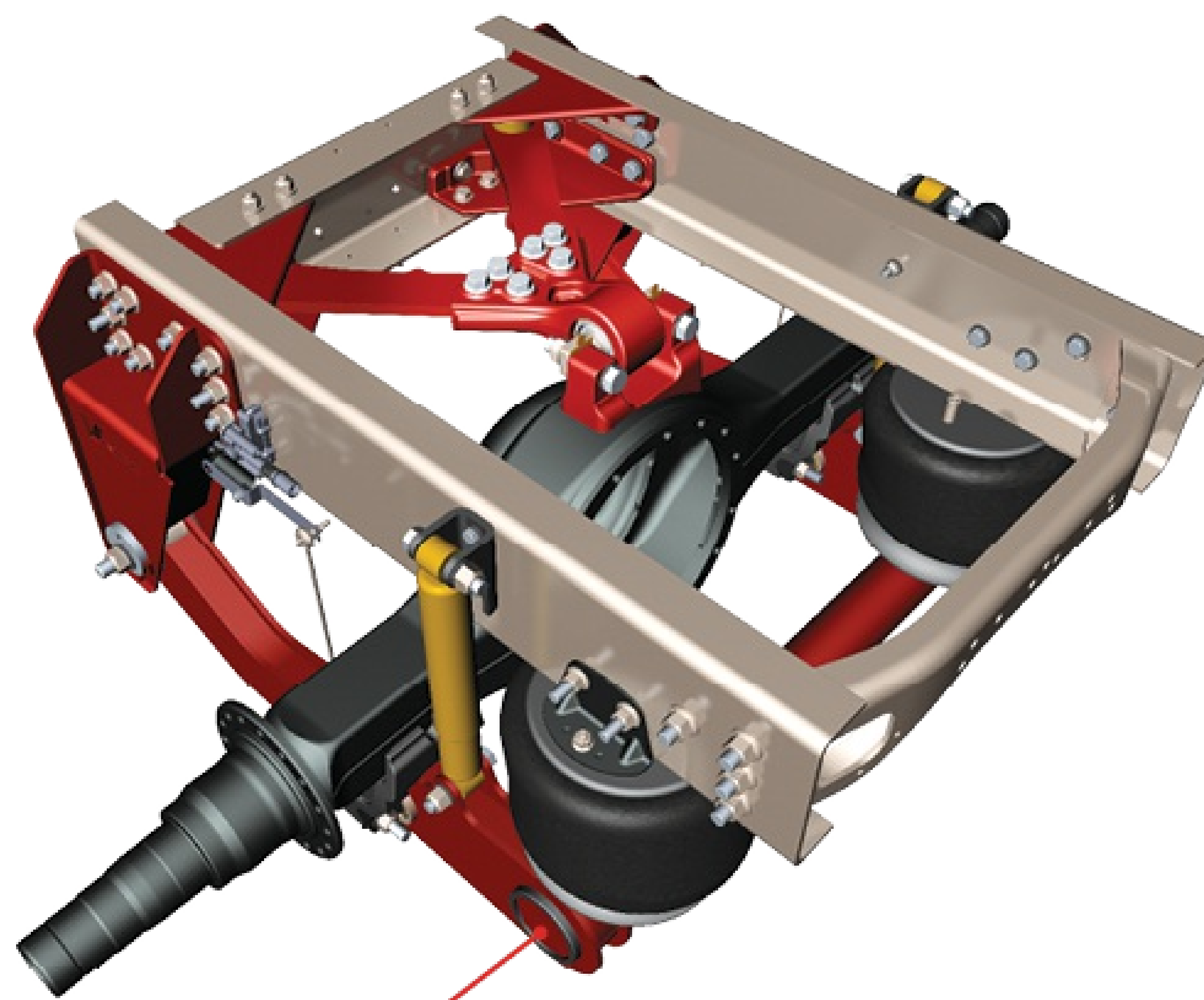

INTEGRATED TRANSVERSE BEAM

EXPERIENCE OF OWNERSHIP

FREIGHTLINER CHASSIS OWNERS CLUB (FCOC):

- **10,000+ Members**
- **Parts and labor discounts** at select Freightliner service locations
- **Nationwide rallies and events** offer excursions to great destinations
- FCOC's comprehensive communications keep owners informed — Quarterly RV Soul magazine published 4x per year
- Members can **purchase Dodge, Chrysler or Jeep at 1% below dealer cost**



OWNER TRAINING

- **30+ Camp Freightliner I classes** at FCCC factory or on-site at rallies every year — comprehensive 2-day training with one-on-one coaching; costs **less than \$300**
- Camp Freightliner II classes at FCCC factory — **pairs owners with a service technician** in the service bay to observe service techniques and ask questions about their chassis
- Fireside Chat seminars — abbreviated training offered at all major rallies and shows

