



2024 SPEC SHEET

# Holiday Rambler Armada

Floor plans: 44B, 44LE

## 5-STAR FEATURES



24/7 factory-direct phone support



ZF Independent Front Suspension with up to 60-Degree Wheel Cut: the tightest turning radius in the industry



Factory-installed, factory-warranted integrated air supply for your tow vehicle brake system



Wheel and column controls pair with OptiView to put every command in easy reach

All-new ergonomic steering wheel  
Prioritizes driver safety



Reduced curb-to-curb turning radius

Eliminates costly tire scrub

Fully integrated & precision tuned to coach model & floorplan



Increased towing capacity

Superior roll stability & handling

Greater durability & longevity

### ENGINE

<b>Make</b>	Cummins L9
<b>Horsepower</b>	450 HP @ 2,100 rpm
<b>Torque</b>	1,250 lb-ft
<b>Brake</b>	VGT (Variable Geometry Turbocharger) Brake (single stage)

### WEIGHT RATINGS

<b>Front GAWR</b>	14,320 lbs
<b>Rear GAWR</b>	20,000 lbs
<b>Tag GAWR</b>	10,000 lbs
<b>Total GVWR</b>	44,320 lbs
<b>Total GCWR</b>	54,320 lbs

### TRANSMISSION

<b>Type</b>	Automatic
<b>Gears</b>	Allison 3000 6-speed

### FUEL

<b>Type</b>	Diesel
<b>Fuel Tank</b>	100 Gallon
<b>Def Tank</b>	13 Gallon

### SUSPENSION

<b>Front</b>	ZF RL80EM
<b>Wheel Cut</b>	60 Degree front wheel
<b>Rear</b>	FCCC V-Ride
<b>Tag</b>	Neway CA-110

### SHOCKS

<b>Make</b>	Sachs custom tuned
-------------	--------------------

### AXLES

<b>Front</b>	ZF Independent
<b>Rear</b>	Detroit DA-RS-21.0-4
<b>Tag</b>	FCCC UltraSteer

### BRAKES

<b>Front</b>	Bendix Air Disc Brakes with ABS
<b>Rear</b>	Meritor Air Drum Brakes with ABS

### COOLING

<b>Radiator</b>	1,335 sq. in., Rear mounted
-----------------	-----------------------------

### RAILS

<b>Front</b>	14.1875" x 2.75" x 0.25"
<b>Rear</b>	12.9375" x 3.0" x 0.25"

### FRAME

<b>Construction</b>	XCM Modular and lowered rear section with Freedom Foundation
---------------------	--------------------------------------------------------------

<b>Wheel Base</b>	285"
-------------------	------

### HITCH

<b>Rating</b>	15,000 lbs
---------------	------------

### TIRES

<b>Make</b>	Michelin X Line Energy Z
<b>Front Size</b>	275/80R 22.5 16-ply
<b>Rear Size</b>	275/80R 22.5 16-ply
<b>Tag Size</b>	275/80R 22.5 16-ply
<b>Wheels</b>	8.25" Aluminum w/ Tire Pressure Monitoring System

### ELECTRICAL

<b>Alternator</b>	160 Amp
<b>Battery</b>	(2) 1,900 CCA @ 0 degrees F

### CONTROLS

<b>Steering Column</b>	TRW Tilt/3" Telescopic
<b>Steering Wheel</b>	DriveTech steering wheel w/ OptiView controls
<b>Instruments</b>	OptiView LCD display, Daytime Running Lights, Push Button Start, Suspended Pedals
<b>Safety</b>	Automatic Traction Control (ATC)

Some Roadwatch features may be optional. See your sales associate for more information.

### WARRANTY

<b>Basic Chassis / Drivetrain</b>	5 years, 100,000 mi
<b>Engine</b>	5 Years / 100,000 mi.
<b>Transmission</b>	5 years, 200,000 mi
<b>Battery</b>	1 year, 100,000 mi
<b>Corrosion / Brightwork</b>	6 months unlimited
<b>Frame Rails / Cross Member</b>	5 years, 100,000 mi

# Holiday Rambler Armada

Floor plans: 44B, 44LE

## 5-STAR FEATURES



### SERVICE

The RV industry's most comprehensive service and support coverage with **450+ Freightliner service locations, 90+ Oasis RV Specialist locations and 24/7 Factory-Direct support for the life of the coach.**

24/7 factory-direct service — talk directly with factory service advisors who average 18 years of experience.



Nationwide parts distribution centers (PDC Centers) provide expedited parts delivery through centralized Freightliner parts database.



- 24/7 Direct: free mobile app for one click, on-the-go support is available on Apple and Android — search "Freightliner 24/7"
- Call or email FCCC technicians 24/7, locate servicing dealers, and provide feedback on service experience
- Allows maintenance logs to be stored in the cloud and shared across devices
- Provides access to service checklist, owner and maintenance manuals, dash light descriptions, FAQs and more



With **automotive-like feel and maneuverability**, the ZF™ Independent Front Suspension delivers the tightest turns in the industry.

- Up to 60-degree wheel cut offers **superior maneuverability and turning radius**
- Double-wishbone design offers **smooth ride and redefined handling**
- **Excellent center feel** and steering response
- Front air-disc brakes with **ABS help maintain control** and significantly **decrease stopping distance**

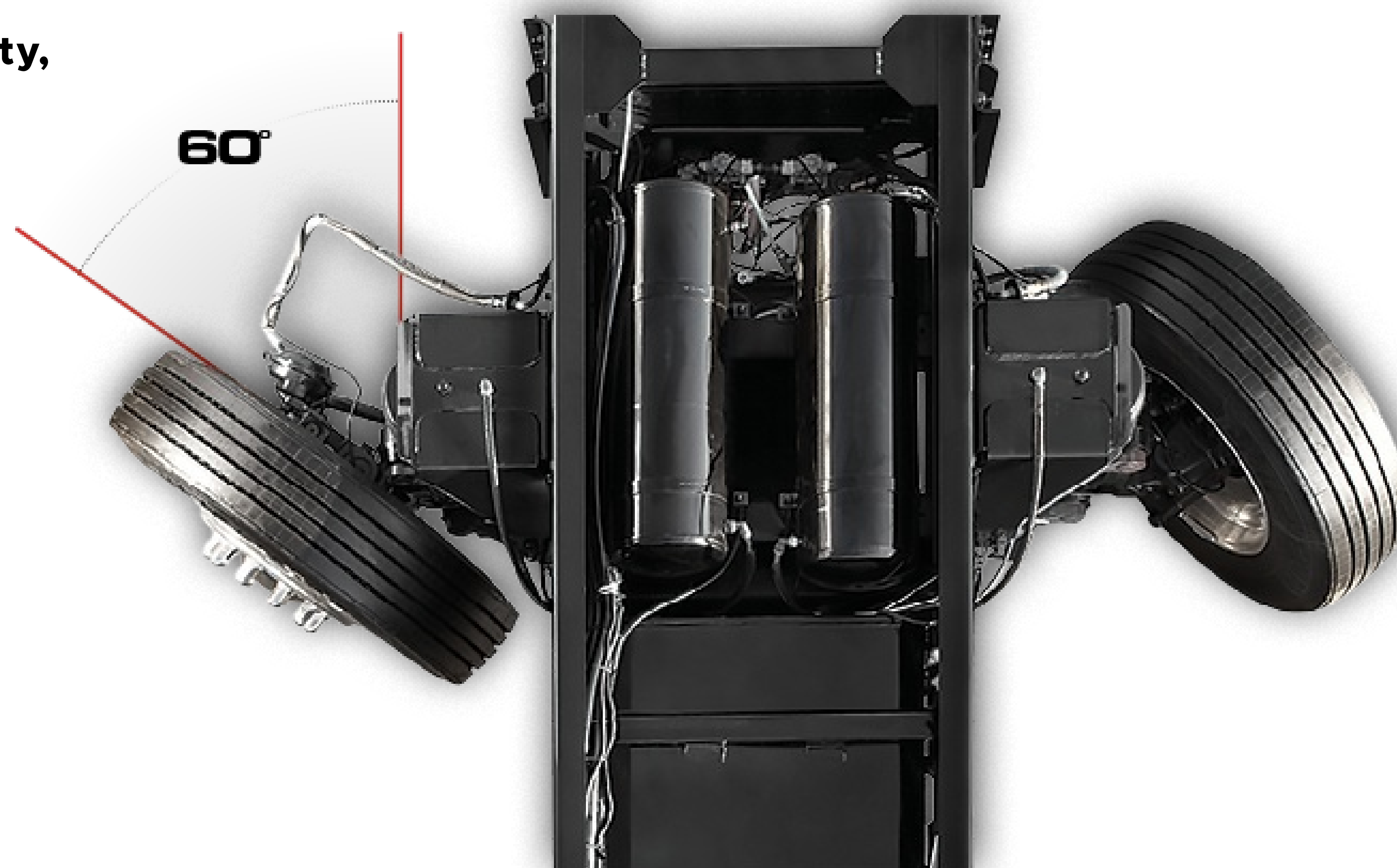

# Holiday Rambler Armada

Floor plans: 44B, 44LE

## 5-STAR FEATURES



### BRAKE SYNC

**Designed by the Freightliner Custom Chassis engineering team, BrakeSync is the only factory-installed, factory-warranted integrated air supply for your tow vehicle's supplemental brake system.**

- Includes automotive-style mounting and quick disconnect air chuck
- Plumbing ensures air pressure to supplemental brake system in the event of air source failure
- Easily visible low air warnings through direct connection to DriveTech via OptiView
- Adaptable to most tow vehicle hardware using air

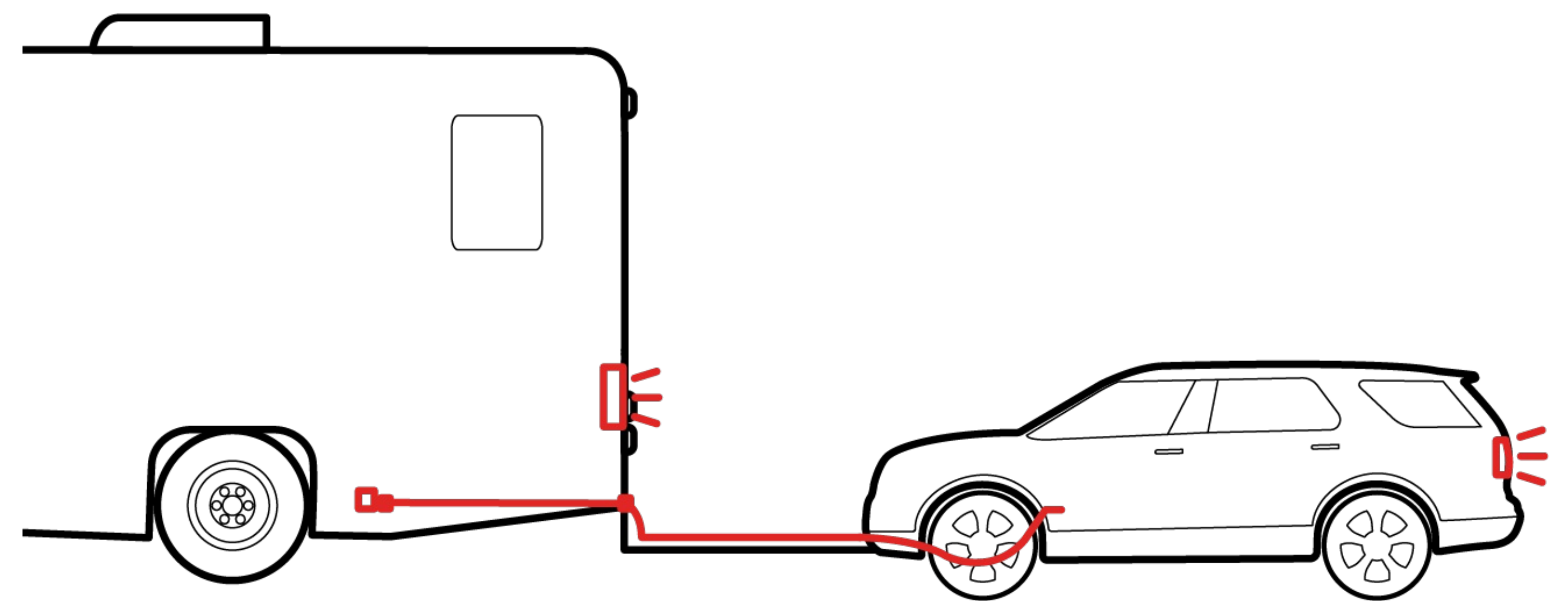

### DRIVETECH

DriveTech rolls together FCCC's latest innovations — like the OptiView all-digital LCD dash display, RoadWatch state-of-the-art safety systems, and FCCC's all-new ergonomic steering wheel and column-mounted controls — into one comfortable, easy-to-use drive console.



# Holiday Rambler Armada

Floor plans: 44B, 44LE

## 5-STAR FEATURES



### OPTIVIEW™

Influenced by Mercedes-Benz®, OptiView® is the first LCD instrument cluster in the RV industry, featuring:

- **Improved interface and steering wheel controls** with anti-glare display, bright graphics, colors, and menus
- **Bluetooth® connectivity** capability

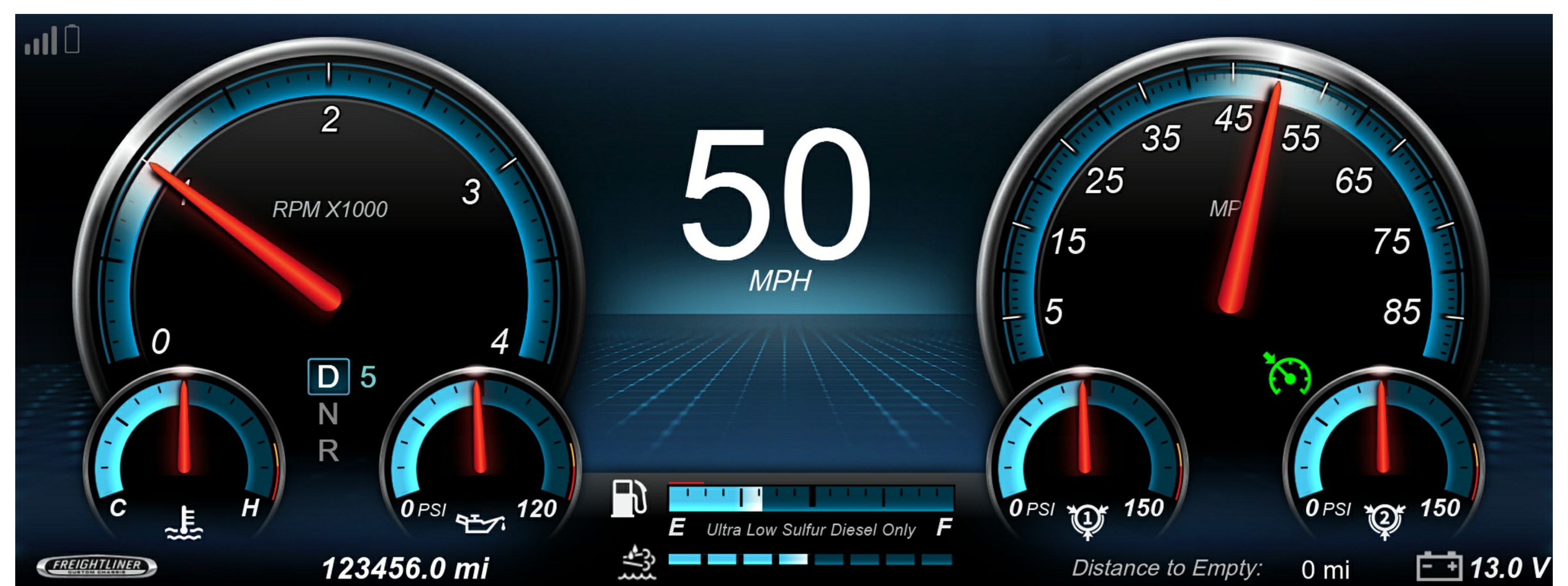

### ULTRASTEER

**Precision-tuned tag axles follow the ideal turning path, eliminating tire scrub and reducing curb-to-curb turning radius by 17%;**

- 12-degree wheel cut allows tag axle to follow the ideal turning path of the coach — **20% tighter turning angle than the nearest competitor**
- Outboard-mounted shocks offer **best-in-class roll stability, greatly enhancing ride and handling**
- Wide track suspension arms (B-Series) provide increased lateral stiffness for **improved handling in sudden maneuvers**
- Auto-locks at 20mph and in reverse; locking-pin utilizes air chamber and dedicated plate for **increased safety**

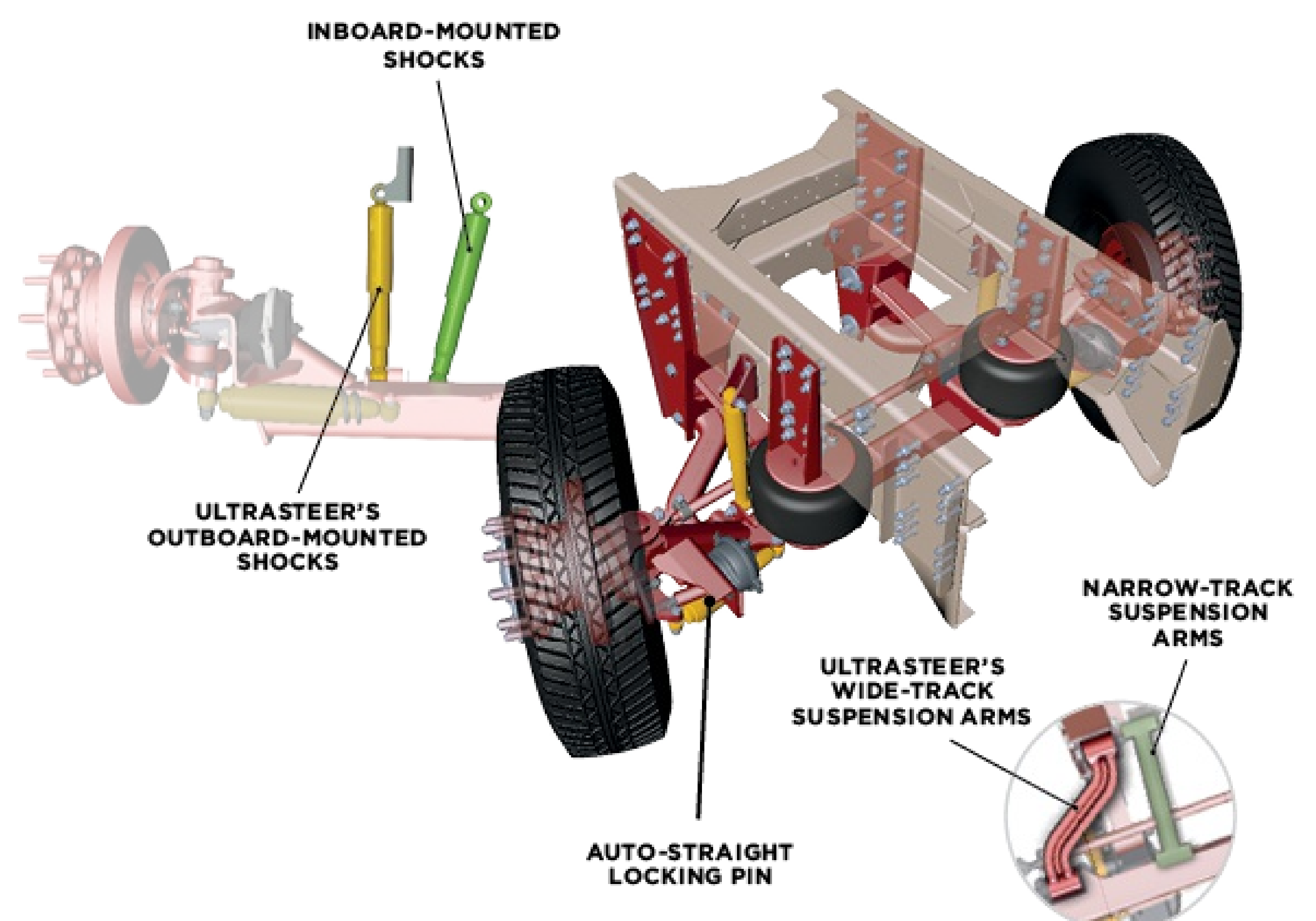

# Holiday Rambler Armada

Floor plans: 44B, 44LE

## 5-STAR FEATURES



### V-RIDE

**Exclusive rear suspension system rated up to 24,000 lbs. for best-in-class cargo capacity, roll stability and overall handling.**

- **More towing capacity** and consistent handling
- V-rod connection dissipates suspension forces — **reducing stress for greater durability and longevity**
- Transverse beam integrated with the trailing arm form a single-piece U-shaped assembly — **enhancing stability at all speeds while adding durability and reducing maintenance**

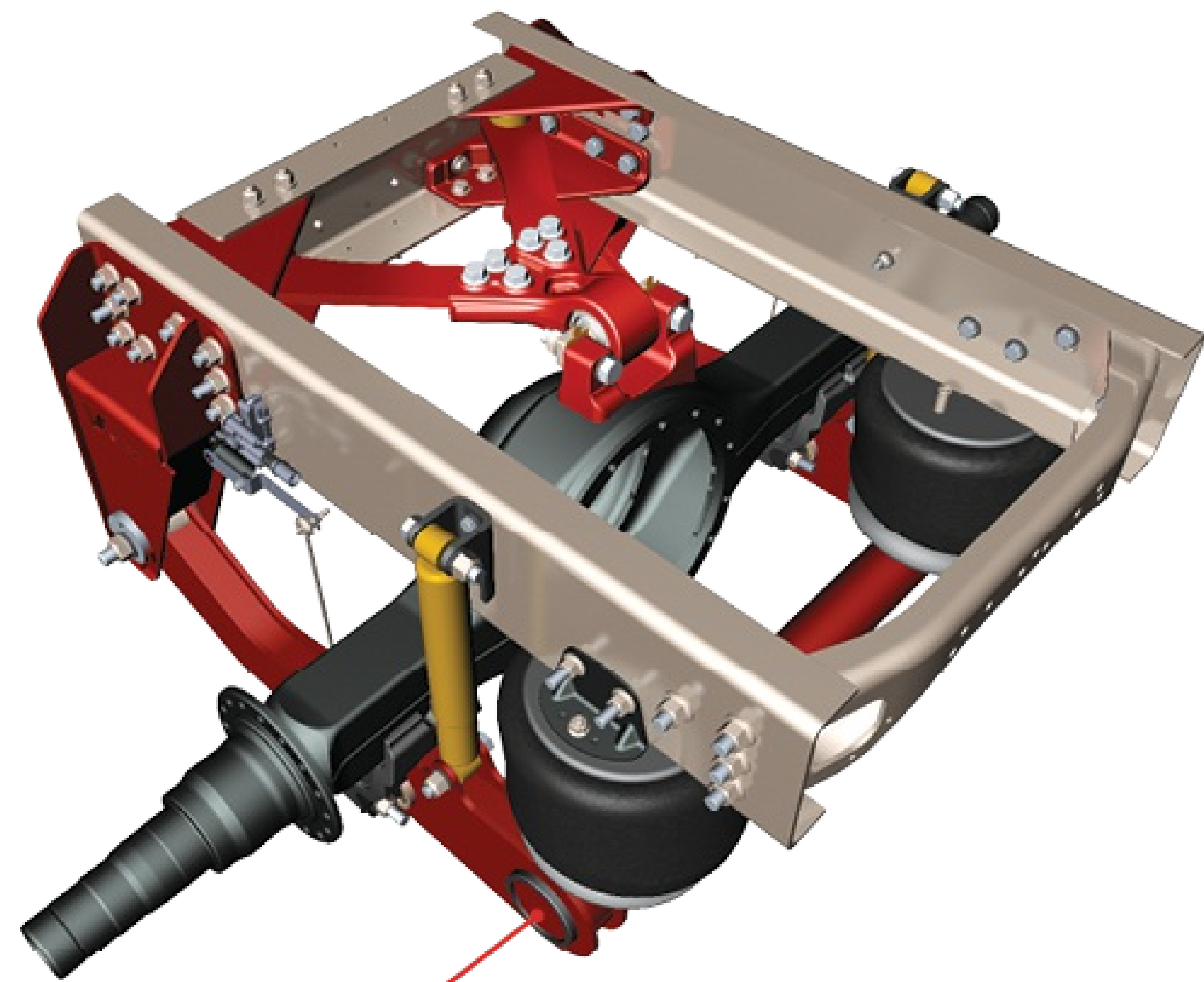

INTEGRATED TRANSVERSE BEAM

## EXPERIENCE OF OWNERSHIP

### FREIGHTLINER CHASSIS OWNERS CLUB (FCOC):

- **10,000+ Members**
- **Parts and labor discounts** at select Freightliner service locations
- **Nationwide rallies and events** offer excursions to great destinations
- FCOC's comprehensive communications keep owners informed — Quarterly RV Soul magazine published 4x per year
- Members can **purchase Dodge, Chrysler or Jeep at 1% below dealer cost**



### OWNER TRAINING

- **30+ Camp Freightliner I classes** at FCCC factory or on-site at rallies every year — comprehensive 2-day training with one-on-one coaching
- Camp Freightliner II classes at FCCC factory — **pairs owners with a service technician** in the service bay to observe service techniques and ask questions about their chassis
- Fireside Chat seminars — abbreviated training offered at all major rallies and shows

