

Tiffin Byway

Floor plans: 38CL, 38BL

5-STAR FEATURES



24/7 factory-direct phone support

DRIVETECH

Wheel and column controls pair with OptiView to put every command in easy reach

All-new ergonomic steering wheel

Prioritizes driver safety

ROADWATCH

Suite of state-of-the-art safety systems for driver confidence in all conditions and maneuvers

V-RIDE

Increased towing capacity

Superior roll stability & handling

Greater durability & longevity

ENGINE

Make	Cummins B6.7
Horsepower	340 HP @ 2,600 rpm
Torque	700 lb-ft
Brake	VGT (Variable Geometry Turbocharger) Brake (single stage)

WEIGHT RATINGS

Front GAWR	10,410 lbs
Rear GAWR	19,000 lbs
Tag GAWR	N/A
Total GVWR	29,410 lbs
Total GCWR	33,000 lbs

TRANSMISSION

Type	Automatic
Gears	Allison 2500 6-speed

FUEL

Type	Diesel
Fuel Tank	90 Gallon
Def Tank	13 Gallon

SUSPENSION

Front	NEWAY AS120
Wheel Cut	55 Degree front wheel
Rear	FCCC V-Ride

SHOCKS

Make	Sachs custom tuned
-------------	--------------------

AXLES

Front	Detroit DA-F-10.5-3
Rear	Detroit DA-RS-19.0-2

BRAKES

Front	Bendix Air Disc Brakes with ABS
Rear	Meritor CAM Brakes with ABS

COOLING

Radiator	1,335 sq. in., Rear mounted
-----------------	-----------------------------

RAILS

Straight	9.125" x 2.81" x 0.3125"
-----------------	--------------------------

FRAME

Construction	Straight Rail Chassis with Formed Rail for Lowered Engine
Wheel Base	252"

HITCH

Rating	Supplied by OEM
---------------	-----------------

TIRES

Make	Michelin XRV
Front Size	255/80R 22.5 14-ply
Rear Size	255/80R 22.5 14-ply
Wheels	8.25" Aluminum Tire Pressure Monitoring System

ELECTRICAL

Alternator	160 Amp Delco Remy
Battery	(2) 1,900 CCA @ 0 degrees F

CONTROLS

Steering Column	ZF Tilt/Telescoping with Foot Pedal
Steering Wheel	DriveTech Steering Wheel w/ Optiview Controls
Instruments	OptiView LCD display, Daytime Running Lights, Auto Headlamps, Adjustable Suspended Brake and Accelerator Pedals
Safety	RoadWatch featuring Collision Mitigation (forward warning and active braking), Electronic Stability Control (ESC) with Roll Stability Support (RSS), Adaptive Cruise Control (ACC), Automatic Traction Control (ATC)

WARRANTY

Basic Chassis / Drivetrain	5 years, 100,000 mi
Engine	5 Years / 100,000 mi.
Transmission	5 years, 200,000 mi
Battery	1 year, 100,000 mi
Corrosion / Brightwork	6 months unlimited
Frame Rails / Cross Member	5 years, 100,000 mi

Tiffin Byway

Floor plans: 38CL, 38BL

5-STAR FEATURES



SERVICE

The RV industry's most comprehensive service and support coverage with **450+ Freightliner service locations, 90+ Oasis RV Specialist locations and 24/7 Factory-Direct support for the life of the coach.**

24/7 factory-direct service — talk directly with factory service advisors who average 18 years of experience.



Nationwide parts distribution centers (PDC Centers) provide expedited parts delivery through centralized Freightliner parts database.



- 24/7 Direct® free mobile app for one click, on-the-go support is available on Apple and Android — search "Freightliner 24/7"
- Call or email FCCC technicians 24/7, locate servicing dealers, and provide feedback on service experience
- Allows maintenance logs to be stored in the cloud and shared across devices
- Provides access to service checklist, owner and maintenance manuals, dash light descriptions, FAQs and more

DRIVETECH

DriveTech rolls together FCCC's latest innovations — like the OptiView all-digital LCD dash display, RoadWatch state-of-the-art safety systems, and FCCC's all-new ergonomic steering wheel and column-mounted controls — into one comfortable, easy-to-use drive console.



Tiffin Byway

Floor plans: 38CL, 38BL

5-STAR FEATURES



OPTIVIEW™

Influenced by Mercedes-Benz®, OptiView™ is the first LCD instrument cluster in the RV industry, featuring:

- **Improved interface and steering wheel controls** with anti-glare display, bright graphics, colors, and menus
- **Bluetooth® connectivity** capability

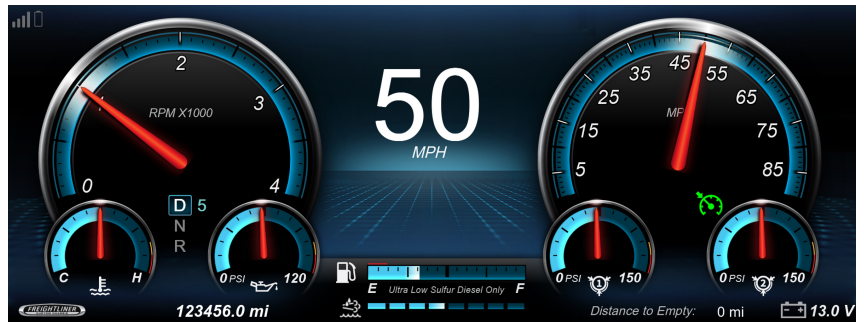

ROADWATCH

RoadWatch is the ultimate RV Safety System, assisting the driver with control of the coach in all road conditions and maneuvers. Reference your spec sheet to find which of the following features are included on your coach.

- Collision Mitigation (forward warning and active braking)
- Adaptive Cruise Control (ACC)
- Electronic Stability Control (ESC) with Roll Stability Control (RSC)
- Automatic Traction Control (ATC)
- Mobileye Sensor Detection

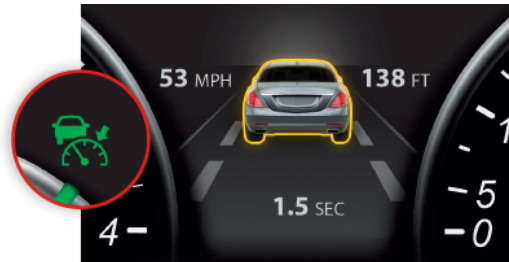

Some RoadWatch features may be optional. See your sales associate for more information.

Tiffin Byway

Floor plans: 38CL, 38BL

5-STAR FEATURES



V RIDE

Exclusive rear suspension system rated up to 24,000 lbs. for best-in-class cargo capacity, roll stability and overall handling.

- **More towing capacity** and consistent handling
- V-rod connection dissipates suspension forces — **reducing stress for greater durability and longevity**
- Transverse beam integrated with the trailing arm form a single-piece U-shaped assembly — **enhancing stability at all speeds while adding durability and reducing maintenance**

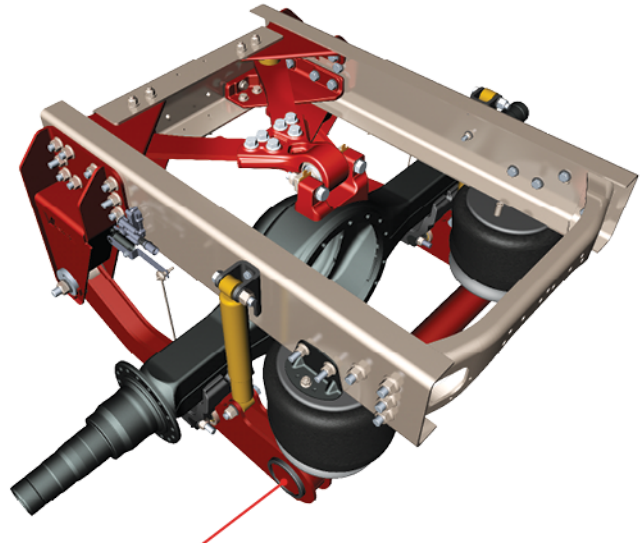

INTEGRATED TRANSVERSE BEAM

EXPERIENCE OF OWNERSHIP

FREIGHTLINER CHASSIS OWNERS CLUB (FCOC):

- **10,000+ Members**
- **Parts and labor discounts** at select Freightliner service locations
- **Nationwide rallies and events** offer excursions to great destinations
- FCOC's comprehensive communications keep owners informed — Quarterly *RV Soul* magazine published 4x per year
- Members can **purchase Dodge, Chrysler or Jeep at 1% below dealer cost**



OWNER TRAINING

- **30+ Camp Freightliner I classes** at FCCC factory or on-site at rallies every year — comprehensive 2-day training with one-on-one coaching
- Camp Freightliner II classes at FCCC factory — **pairs owners with a service technician** in the service bay to observe service techniques and ask questions about their chassis
- Fireside Chat seminars — abbreviated training offered at all major rallies and shows

