

# Tiffin Phaeton - Powerglide XC

Floor plans: 40IH

## 5-STAR FEATURES



24/7 factory-direct phone support

### BRAKE SYNC

Factory-installed, factory-warranted supplemental braking system for your luxury RVs with FCCC chassis.

### DRIVETECH

Wheel and column controls pair with OptiView to put every command in easy reach  
All-new ergonomic steering wheel  
Prioritizes driver safety

### 60°

ZF Independent Front Suspension with up to 60-Degree Wheel Cut: the tightest turning radius in the industry

### ROADWATCH

Suite of state-of-the-art safety systems for driver confidence in all conditions and maneuvers

### V-RIDE

Increased towing capacity  
Superior roll stability & handling  
Greater durability & longevity

ENGINE	
<b>Make</b>	Cummins L9 Diesel
<b>Horsepower</b>	450 HP @ 2,100 rpm
<b>Torque</b>	1,250 lb-ft
<b>Brake</b>	Engine Compression Brake (three stage)
WEIGHT RATINGS	
<b>Front GAWR</b>	16,000 lbs
<b>Rear GAWR</b>	24,000 lbs
<b>Tag GAWR</b>	N/A
<b>Total GVWR</b>	40,000 lbs
<b>Total GCWR</b>	Reference OE Specifications
TRANSMISSION	
<b>Type</b>	Automatic
<b>Make</b>	Allison 3000 6-speed
FUEL	
<b>Type</b>	Diesel
<b>Fuel Tank</b>	100 Gallon
<b>Def Tank</b>	13 Gallon
SUSPENSION	
<b>Front</b>	ZF Independent IFS
<b>Wheel Cut</b>	60 Degree front wheel
<b>Rear</b>	FCCC V-Ride
SHOCKS	
<b>Make</b>	Koni
AXLES	
<b>Front</b>	ZF Independent
<b>Rear</b>	Detroit DA-RS-23.0-4
BRAKES	
<b>Front</b>	Bendix Air Disc Brakes with ABS
<b>Rear</b>	Bendix Drum Brakes with ABS
COOLING	
<b>Radiator</b>	1,335 sq. in., Rear mounted

RAILS	
<b>Upper</b>	9.0" x 2.75" x 0.25"
<b>Front</b>	14.1875" x 2.75" x 0.25"
<b>Rear</b>	12.44" x 2.75" x 0.25"
FRAME	
<b>Construction</b>	Raised Rail Chassis with Formed Rail for Lowered Engine
<b>Wheel Base</b>	266"
HITCH	
<b>Rating</b>	Supplied by OEM
TIRES	
<b>Make</b>	Michelin X Coach Z
<b>Front Size</b>	295/80R 22.5 16-ply
<b>Rear Size</b>	295/80R 22.5 16-ply
<b>Wheels</b>	9" Aluminum w/ Tire Pressure Monitoring System
ELECTRICAL	
<b>Alternator</b>	240 Amp Leece-Neville
<b>Battery</b>	(2) 1,900 CCA @ 0 degrees F
CONTROLS	
<b>Steering Column</b>	ZF Tilt/Telescoping with Foot Pedal
<b>Steering Wheel</b>	Powerglide XC leather steering wheel w/ OptiView Controls
<b>Instruments</b>	OptiView LCD display, Daytime Running Lights, Auto Headlamps, Adjustable Suspended Brake and Accelerator Pedals
<b>Safety</b>	RoadWatch featuring Collision Mitigation (forward warning and active braking), Adaptive Cruise Control (ACC), Electronic Stability Control (ESC) with Roll Stability Support (RSS), Automatic Traction Control (ATC)
WARRANTY	
<b>Basic Chassis / Drivetrain</b>	5 years, 100,000 mi
<b>Engine</b>	5 Years / 100,000 mi.
<b>Transmission</b>	5 years, 200,000 mi
<b>Battery</b>	1 year, 100,000 mi
<b>Corrosion / Brightwork</b>	6 months unlimited
<b>Towing</b>	6 months, unlimited
<b>Frame Rails / Cross Member</b>	5 years, 100,000 mi

# Tiffin Phaeton - Powerglide XC

Floor plans: 40IH

## 5-STAR FEATURES



My 24/7 Direct is an essential resource for RV owners, designed to enhance your ownership experience with comprehensive support. Key features include tracking annual RV chassis maintenance, locating and contacting Oasis and Elite service centers, accessing Quick Guides, monitoring mileage, and reaching out directly to factory support.

Download the app today on iOS or Android.  
Or access via the web at [My247Direct.com](http://My247Direct.com)

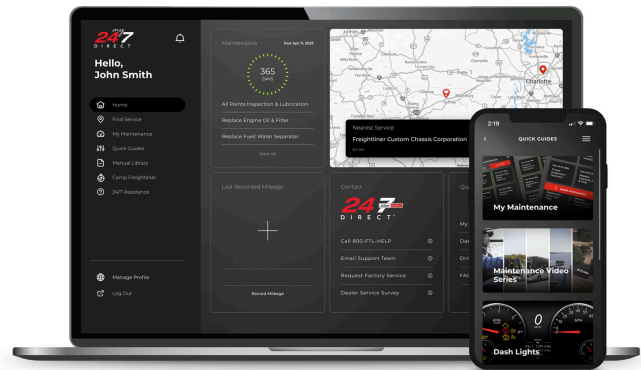

**SCAN TO DOWNLOAD  
THE MOBILE APP TODAY!**



## BRAKE SYNC

Designed by our in-house engineering team, BrakeSync is the only factory-installed, factory-warranted supplemental braking system available on luxury RVs with FCCC chassis today. The easy-to-use moisture drain complies with FMVSS standards and features a unique plumbing approach that ensures air pressure remains available to the supplemental brake system in case of primary or secondary brake (air source) failure.

Additionally, low air warnings are easily visible through a direct connection to DriveTech via OptiView, and a dust cap is provided to keep the hookup clean when not in use.

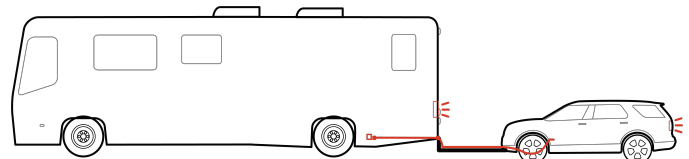

# Tiffin Phaeton - Powerglide XC

Floor plans: 40IH

## 5-STAR FEATURES



### DRIVETECH

DriveTech rolls together an ergonomically designed steering wheel, column controls, the OptiView™ LED instrument cluster, and RoadWatch safety features to create an automotive-like feel and set the industry standard for luxury RV driving.

DriveTech is the first RV driving system to maximize safety by putting every command in one easy-to-reach location. The column-mounted controls put the driver completely in command. Transmission and brake controls are on the right column while the left column provides fingertip access to wiper, headlight and signal controls.



With the coach feel and maneuverability of the ZF Independent Front Suspension (IFS), you'll have the driving confidence and peace-of-mind that comes with knowing you have up to 60-degree wheel cut to access the tightest spaces with minimal backing. Essentially, it feels similar to maneuvering a car.

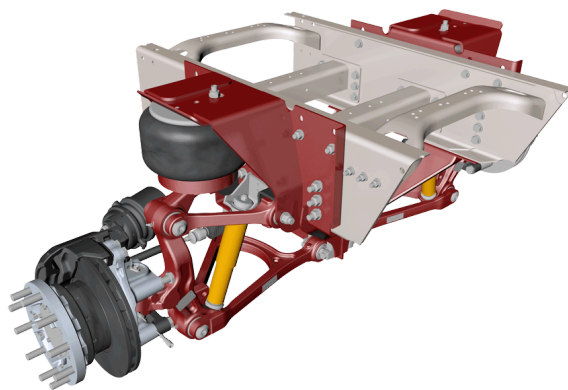

# Tiffin Phaeton - Powerglide XC

Floor plans: 40IH

## 5-STAR FEATURES



OptiView is the first LCD instrument cluster in the RV industry. With design influenced by Mercedes-Benz®, it can handle a 360-degree camera system, Bluetooth connectivity and more.



## ROADWATCH

RoadWatch is the ultimate RV Safety System, assisting the driver with control of the coach in all road conditions and maneuvers.

**Adaptive Cruise Control (ACC) with Collision Mitigation**  
Maintains set cruise speed and automatically adjusts speed when vehicle ahead is detected

**Electronic Stability Control (ESC) with Roll Stability Control (RSC)**  
Reduces the risk of instability while in curve or taking evasive action and actively monitors conditions that can lead to rollover and automatically intervenes at high-risk

**Automatic Traction Control (ATC)**  
Improves stability when driving on low-friction surfaces, as well as improved traction under difficult road conditions

**Mobileye® 360-degree Sensor Detection**  
Interprets data from camera, radar and LiDAR sensors to detect objects and alert the driver to a safer path forward

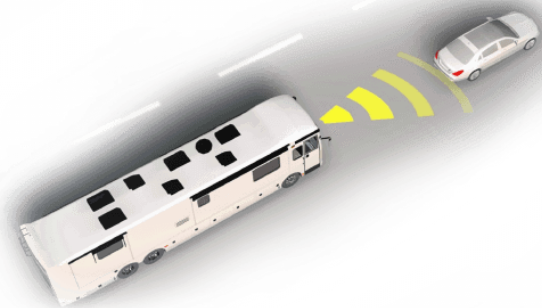
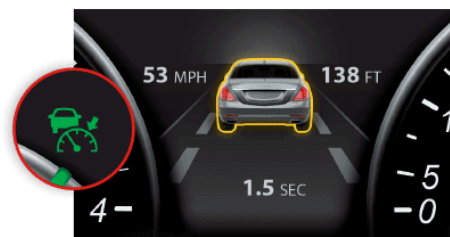

# Tiffin Phaeton - Powerglide XC

Floor plans: 40IH

## 5-STAR FEATURES



Rated up to 24,000 pounds, Freightliner's V-Ride gives RV owners the freedom to choose more amenities and carry more cargo. It also provides superior roll stability, a smoother ride and more stable handling — in any driving condition.

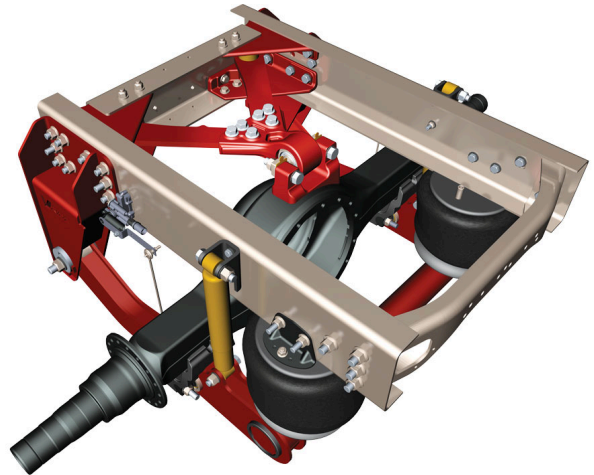

## EXPERIENCE OF OWNERSHIP

### FREIGHTLINER CHASSIS OWNERS CLUB (FCOC):

- **10,000+ Members**
- **Parts and labor discounts** at select Freightliner service locations
- **Nationwide rallies and events** offer excursions to great destinations
- FCOC's comprehensive communications keep owners informed — Quarterly *RV Soul* magazine published 4x per year
- Members can **purchase Dodge, Chrysler or Jeep at 1% below dealer cost**



### OWNER TRAINING

- **30+ Camp Freightliner I classes** at FCCC factory or on-site at rallies every year — comprehensive 2-day training with one-on-one coaching
- Camp Freightliner II classes at FCCC factory — **pairs owners with a service technician** in the service bay to observe service techniques and ask questions about their chassis
- Fireside Chat seminars — abbreviated training offered at all major rallies and shows

